

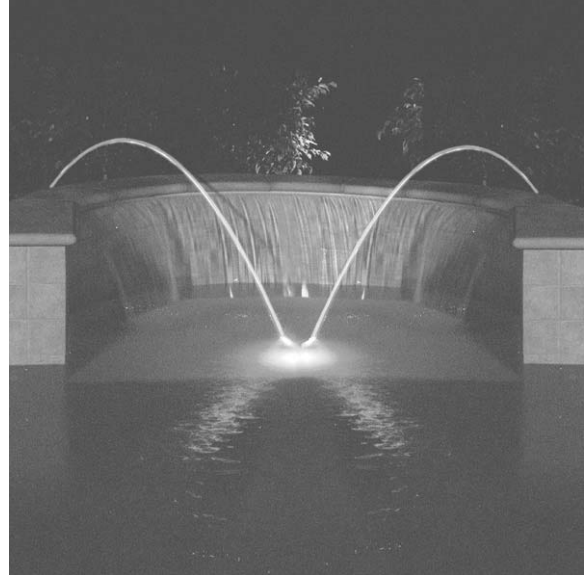

## Installation and Operation Manual



## Jandy<sup>®</sup> Laminar Jet with Deck Box

### **WARNING**

**FOR YOUR SAFETY** - This product must be installed and serviced by a professional pool/spa service technician. The procedures in this manual must be followed exactly. Failure to follow warning notices and instructions may result in property damage, serious injury, or death.

This manual contains important information about the installation, operation and safe use of this product. This information should be given to the owner/operator of this equipment.



## Section 1. General Installation Requirements

This document gives instructions for installing the Jandy Laminar Jet. Read through the instructions completely before starting the procedure.

The Jandy Laminar Jet is designed to provide a clear stream of water that arcs up to a maximum of seven feet (7') high and eight feet (8') out into the water. Its design provides for the option to light the arc of water with fiber optics creating a dazzling nighttime effect. This unique water feature is easily installed and multiple jets can be combined to create spectacular water entertainment.

To properly install this product please review the following installation and maintenance instructions.

### 1.1 Water Source

The Laminar Jet water supply line must be filtered by a cartridge filter (do not use a sand filter). If you are using a dedicated filter - it must be a minimum of 20 square feet. For multiple jet installations, use 100 square feet, such as the Jandy CT100.

### 1.2 Pump

Required minimum pump flow for each Laminar Jet is approximately 10 gallons per minute (gpm). If a dedicated pump is used, a minimum of ½ HP is required and the pump must produce the required flow at a minimum of sixteen feet (16') of head.

### 1.3 Plumbing

Each Laminar Jet requires a 1½" to 2" PVC main feed line with 1" PVC entering the Deck Box. An adjustment valve and a check valve are also required. Valves should be placed as far from the Deck Box as possible to minimize water turbulence (refer to Figures 1 and 2 and Table 1).

### 1.4 Conduit/Fiber Optics (Optional)

If installing fiber optics, each Laminar Jet will require 100 to 150 strand fiber optic cable. 150 strand cable is recommended due to the enhanced lighting effects. Install a 120 VAC line as per the fiber optic manufacturer and local code requirements.

### 1.5 Critical Placement Dimensions

The Laminar Jet can project a maximum of seven feet (7') up and eight feet (8') out into the water. Therefore, ensure the installation is no more than six feet (6') from the *inside* edge of the pool.

**NOTE** To avoid water spray on the deck in high wind areas, place the Laminar Jet closer to the edge of the pool.

**NOTE** The Deck Box lid can only rotate approximately 30 degrees to the left or the right. Therefore, make sure that the Deck Box is positioned towards the desired target location (see *Section 2*) **prior** to completing the installation.

### 1.6 Bonding

**NOTE** Only units with metal mounting brackets require bonding.

The Laminar Jet assembly mounting brackets (metal only) must be bonded to the pool/spa structure using a solid copper conductor, No. 8 AWG or larger. Prepare the unit for bonding prior to installation. Bond the unit using the external lug provided to a steel rod in the deck frame or metal piping within five feet (5') of the inside walls of the pool.

Locate the four bonding lugs on the unit. One lug is mounted on each side of the jet assembly metal mounting bracket (2 total). One lug is mounted on the inner wall of the Deck Box above the water inlet standpipe. The remaining lug is mounted on the outer wall of the box, directly connected to the inner lug.

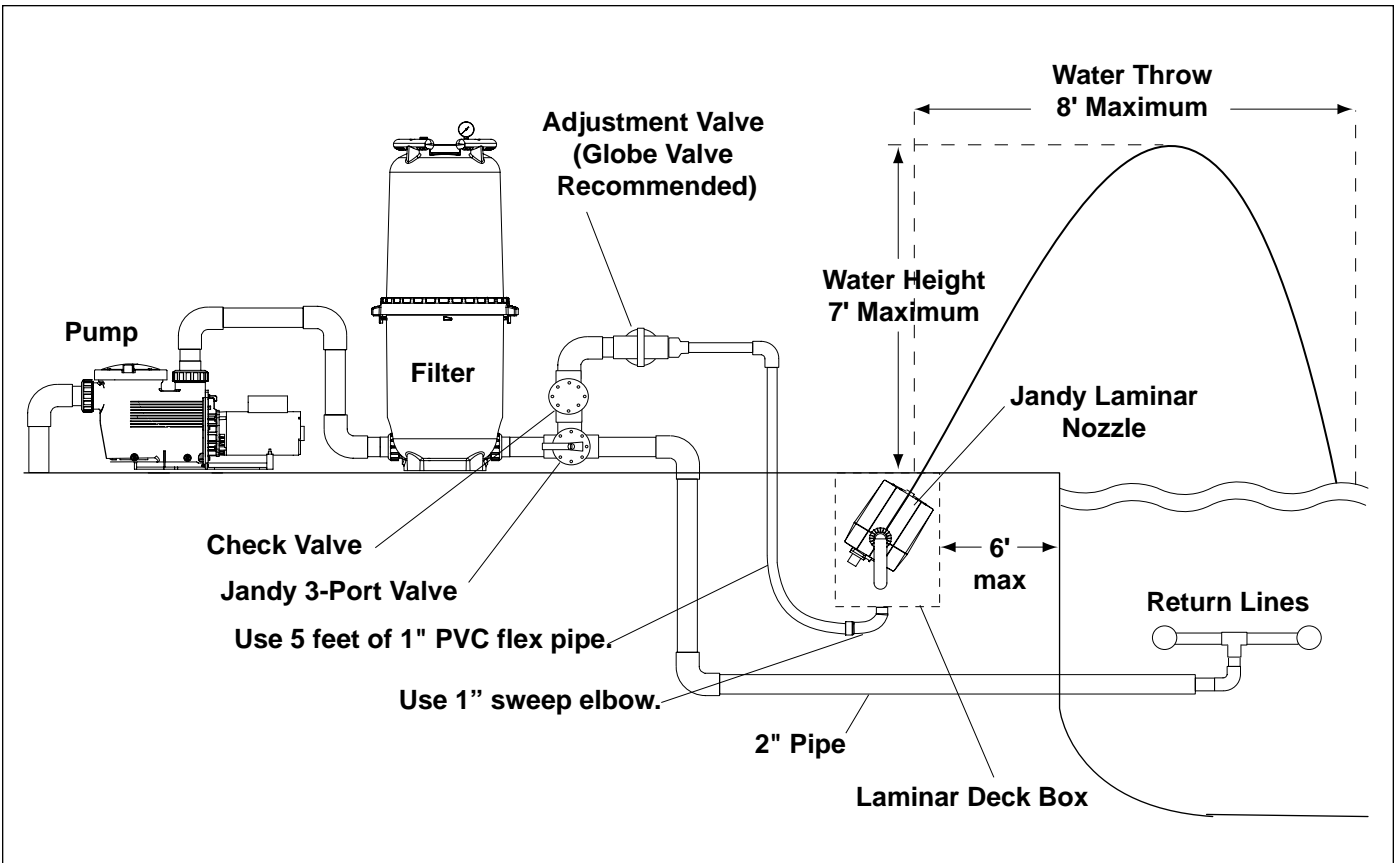

Figure 1. Basic Plumbing Diagram for Laminar Jet with Deck Box

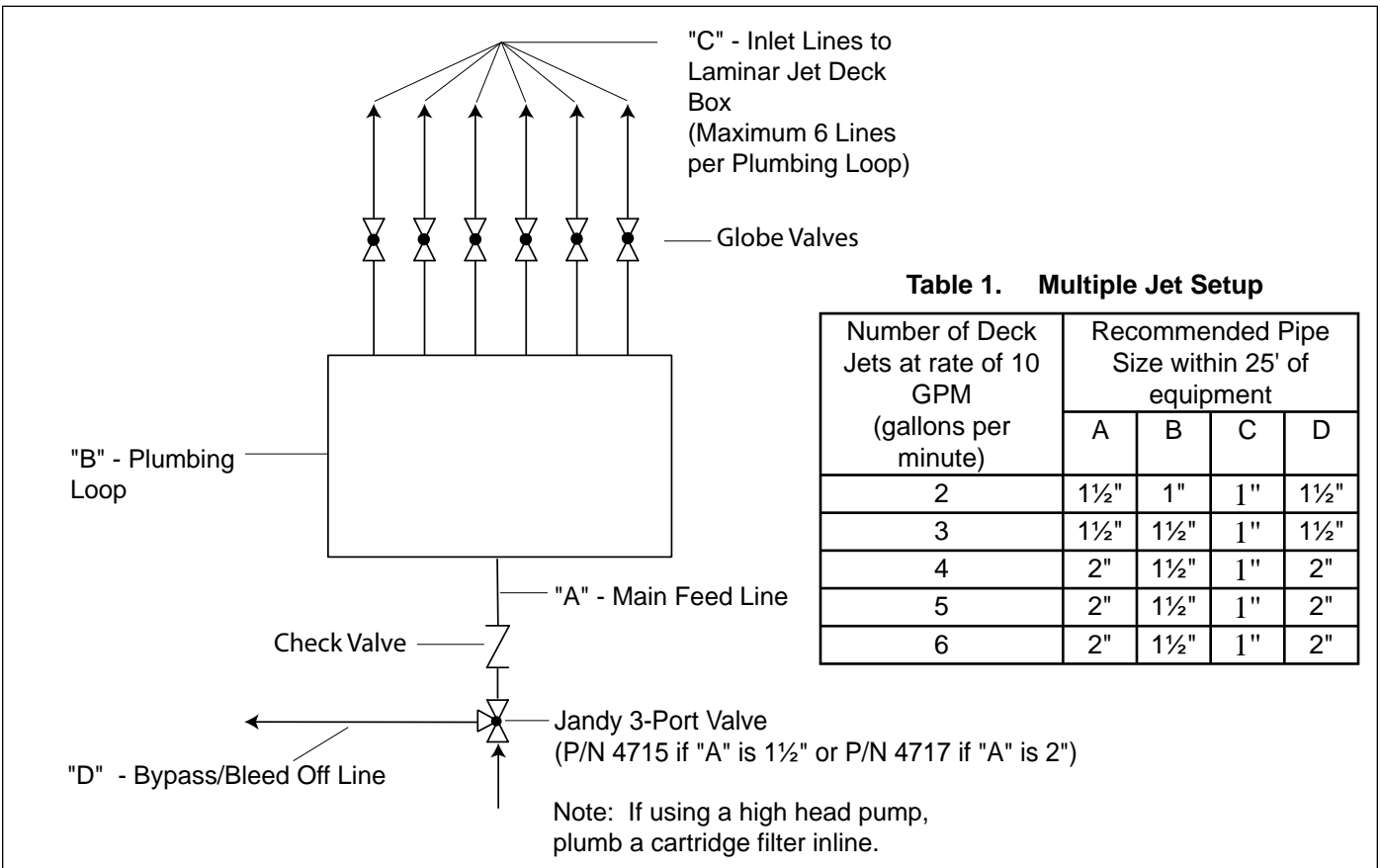

Figure 2. Plan View of Plumbing Loop for Multiple Laminar Jets

## Section 2. Installing the Deck Box

**NOTE** Prior to installing the Jandy Laminar Jet Deck Box, locate the jet opening (slot) in the Deck Box cover. Make sure that this opening is pointing towards the desired target location in the pool. Use the water stand pipe as a reference (see Figure 3). Determining the orientation of the Deck Box will also establish where to place the plumbing and fiber optic conduit.

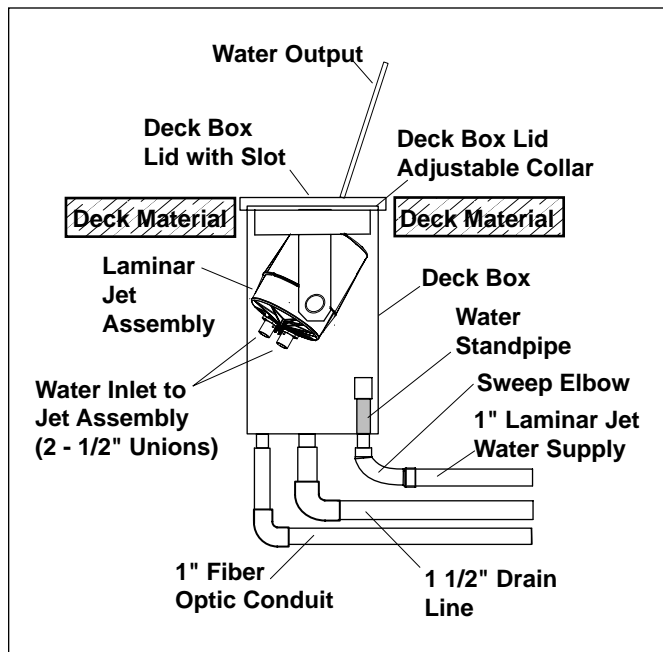

Figure 3. Laminar Jet Deck Box Schematic

**NOTE** The Deck Box lid can only rotate approximately 30 degrees to the left or the right. Therefore, make sure that the Deck Box is positioned towards the desired target location **prior** to completing the installation.

### 2.1 In-deck Installation

1. Dig the hole for the Deck Box approximately twenty-four inches (24") deep and eighteen inches (18") in diameter. This will ensure enough room for positioning the box and laying out the plumbing. This depth also allows for the addition of a layer of pea gravel ( $\frac{1}{8}$  to  $\frac{1}{4}$  size) for stability and additional drainage.

2. Lift up the Deck Box lid and adjustable deck lid collar from the Deck Box (see Figure 4). Notice that the Laminar Jet assembly is connected to the Deck Box lid as one unit. Disconnect the two (2)  $\frac{1}{2}$ " unions located on the bottom of the Laminar Jet assembly (see Figure 3). Set the lid/jet assembly aside.

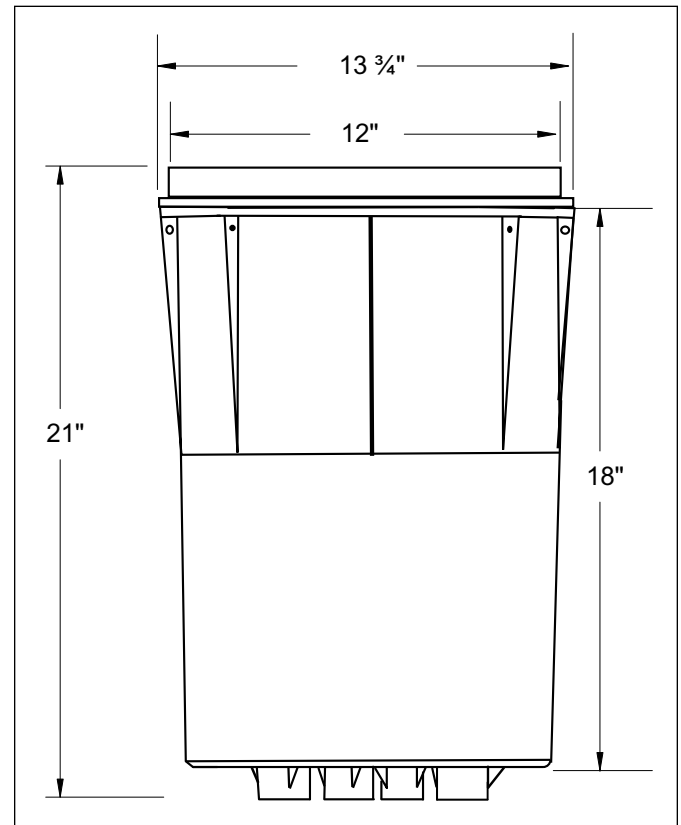

Figure 4. Deck Box Dimensions

3. Set the Deck Box in the hole. The Deck Box should sit deep enough so that the upper edge of the box will be approximately one and one half to two inches ( $1\frac{1}{2}$ "-2") below the surface of the finished deck, after the deck material is poured.

**NOTE** To ensure that the box stays upright while installing **and** leveling the unit, place a six inch (6") length of one and one half inch ( $1\frac{1}{2}$ ") PVC pipe in the construction support socket located on the bottom of the box (see Figure 5).

4. Level the Deck Box. To hold the box in place while the deck is poured, secure the box by tying it with tie wire to the steel framework of the deck.

- Plumb the incoming, filtered water supply to the one inch (1") hub located on the bottom of the Deck Box marked **Inlet** (see Figure 5). The filtered water supply must include an adjustment valve and check valve (see Figures 1 and 2).

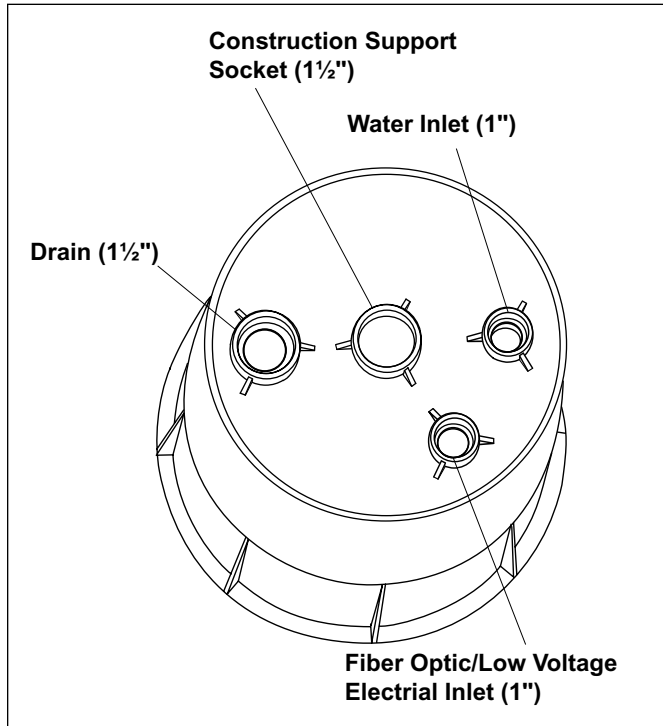

Figure 5. Deck Box - Bottom View

**⚠ Caution**

Deck Box is made of ABS. Use Weld-On 793 or 794 ABS-PVC Cement to glue Schedule 40 PVC.

- Plumb the conduit for the fiber optic cable to the one inch (1") hub located on the bottom of the Deck Box marked **Fiber Optic/Low Voltage Electrical** (see Figure 5). Refer to Section 3 for fiber optic installation.

**NOTE** This hub is also used to install the two (2) conductor, eighteen (18) gauge, stranded cable for the optional LPC4 light pulse control system.

- Plumb in the one and one-half inch (1½") drain line marked Drain. Adequate drainage must be provided to box.

**NOTE** Proper drainage to the Deck Box is critical to avoid damage to the Laminar Jet assembly.

- (*For units with metal mounting brackets only.*) To bond the Laminar Jet, connect one end of a copper wire to the external lug located on the box bottom and the other end to the steel frame of the deck.
- Verify the Deck Box is level.
- Place the adjustable deck lid collar back on the box. This collar allows the installer to make fine adjustments when leveling the box to be flush with the deck's finished surface. Set the collar at the finished deck level and pour the deck.

## 2.2 Out-of-deck/Planter Box Installation

**NOTE** Do not install the Jandy Laminar Jet Deck Box in an area prone to run-off or flooding.

**NOTE** The Deck Box lid can only rotate approximately 30 degrees to the left or the right. Therefore, make sure that the Deck Box is positioned towards the desired target location *prior* to completing the installation.

- Dig the hole for the Deck Box approximately twenty-four inches (24") deep and eighteen inches (18") in diameter. This will ensure enough room for positioning the box and laying out the plumbing. The dimensions allow for the addition of a layer of pea gravel (1/8 to 1/4 size) for drainage, as well as room to pour concrete around the outside of the box for stability.

**NOTE** Proper drainage to the Deck Box is critical to avoid damage to the Laminar Jet assembly.

- Lift up the lid/jet assembly and adjustable deck lid collar from the Deck Box. Disconnect the two (2) ½" unions located on the bottom of the Laminar Jet. Set the lid/jet assembly aside.

**NOTE** To ensure that the box stays upright while installing and leveling the unit, place a six inch (6") length of one and one half inch (1½") PVC pipe in the construction support socket located on the bottom of the box (see Figure 5).

- Set the Deck Box in the hole. The box should be approximately one and one-half to two inches (1½"-2") *above* the finished grade in the planter.

**NOTE** Unlike the in-deck installation, the Deck Box cover cannot be flush with the finished grade. It must sit slightly above the surface to prevent water and debris from seeping into the box.

4. Level the Deck Box. To hold the box in place, position a six inch (6") length of one and one half inch (1½") PVC pipe in the construction support socket located on the bottom of the box (see Figure 5). In include an adjustment valve and check valve (see Figures 1 and 2).
5. Plumb the incoming, filtered water supply to the one inch (1") hub located on the bottom of the Deck Box marked **Inlet** (see Figure 5). The filtered water supply must include an adjustment valve and check valve (see Figures 1 and 2).

**⚠ Caution**

Deck Box is made of ABS. Use Weld-On 793 or 794 ABS-PVC Cement to glue Schedule 40 PVC.

6. Plumb the conduit for the fiber optic cable to the one inch (1") hub located on the bottom of the Deck Box marked **Fiber Optic/Low Voltage Electrical**. Refer to Section 3 for fiber optic installation.

**NOTE** This hub is also used to install the two (2) conductor, eighteen (18) gauge, stranded cable for the optional LPC4 light pulse control system.

7. Plumb in the one and one-half inch (1½") drain line marked **Drain**. Adequate drainage must be provided to box.
8. *(For units with metal mounting brackets only.)* Connect one end of a copper wire to the external lug located on the box bottom. Connect the other end to the steel rod used to stake the Deck Box, or bond per the National Electrical Code.
9. Fill in the hole surrounding the Deck Box with concrete or suitable backfill material for stability in the ground.
10. Place the adjustable deck lid collar back on the box.

### 2.3 Pressure Test Water Lines

Connect the two (2) ½" unions removed from the Laminar Jet in *Section 2.1, Step 2* (or *Section 2.2, Step 2* for out-of deck installation) together. This will provide an air/water tight closed loop during the pressure test.

**NOTE** This same procedure can be used if you need to winterize the system or service the unit.

### 2.4 Flush Water Lines

It is important that prior to reinstalling the Laminar Jet and Deck Box lid, the installer must turn on the water source and *flush the lines of any debris*.

## Section 3. Fiber Optic Installation

### 3.1 Items Required

Tools	Utility knife or hot knife; Heat gun or propane torch.
Cable	Each jet requires 100 to 150 strands of fiber optic cable. Do not use more than forty feet (40') of cable per nozzle as light output will be diminished.
Illuminator	Use illuminator with sufficient capacity of lighting effect intended.
Additional Materials	Electrical tape; Silicon (RTV)

### 3.2 Installation

1. Remove six inches (6") of the cable jacket.
2. Using black electrical tape, tightly tape over the exposed fiber leaving approximately ½" exposed fiber at the end of the cable. The tape prevents the individual fibers from separating.
3. With a heat knife, cut the fiber optic cable so that the cable end is a flat surface. For best results, heat knife to cherry red.

**NOTE** Do not cut the fiber ends too close to the taped edge. Leave a ¼" distance between the cable end and the end of the taped edge. This will prevent adhesive on the tape from melting and getting on the ends of the fiber optic strands.

4. Slide the completed fiber optic cable through the Heyco waterproof fitting and up the tube (located at the bottom of the jet) until the cable bottoms out on the lens inside unit. Secure the fiber by tightening the waterproof fitting.

**NOTE** Allow at least two feet (2') of extra fiber optic cable in the Deck Box to allow the Laminar Jet to be easily removed.

5. Fill the electrical conduit between the opening and the fiber optic cable with RTV silicon to prevent water from entering the conduit. Let dry. The unit is now ready for operation.
6. Install illuminator and attach fiber optic cable according to instructions supplied with the illuminator.

## Section 4. Starting the System

### 4.1 Install Jet Assembly

1. Disconnect the two unions that were attached together for pressure testing in *Section 2.3*.
2. Flush water lines to clear debris. Lines must be clear of debris *before* attaching the Laminar Jet assembly.
3. Connect the two unions to the appropriate ports of Laminar Jet and Deck Box lid.

### 4.2 Set up Jet

Recall that the Deck Box lid and Laminar Jet are attached to each other. To aim the jet, turn the lid with the slot facing the pool until the stream reaches the intended target area of the pool.

1. Turn on the water at a reduced rate and slowly fill the unit. When the unit is filled, increase the water supply until the jet streams reach their intended targets.
2. Use the main valve at the equipment pad to make final adjustments to the overall water height of the jets.

**NOTE** Laminar Jets are sensitive to wind, earth movement and equipment vibration. Secure the Laminar Jet and Deck Box to minimize vibration. Periodic stream distortion caused by pump vibrations and motor electrical fluctuations is normal and not indicative of a nozzle defect. Also, occasionally a nozzle will "burp" due to pumped air collecting in the nozzle body. This is normal and will occur until all air is purged from the piping system. Trapped air can also cause slight distortion in water action. It is imperative that all air is removed to ensure proper water feature operation.

**NOTE** To adjust the angle of the jet, lift the Deck Box lid and move the Laminar Jet up or down to increase or decrease the angle. The angle can be adjusted approximately 15 degrees. The Laminar Jet is installed on two pivots. Loosen the union nuts on the pivots and adjust the jet angle. Once you are satisfied with the angle and location of the jet, tighten the union nuts. Secure the Deck Box lid to the Deck box collar, using two #10 by 1½", Phillips, flat head stainless steel screws (see Figure 6). It is recommended to drill 1/8" pilot holes in the lid. Then the screws can be threaded into the holes. This will complete the installation and secure the jet from movement.

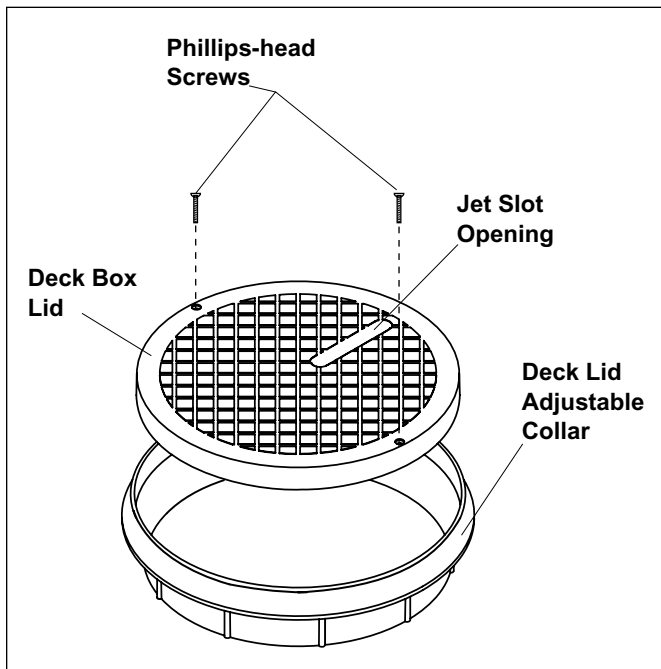

Figure 6. Deck Box Lid with Collar

## Section 5. General Maintenance and Troubleshooting

Perform routine maintenance on the filter to ensure trouble-free nozzle operation. Be careful not to allow debris to enter the inlet plumbing when cleaning filters. *Always flush lines after cleaning and backwash of filters.*

### 5.1 Clogged Nozzle

1. If nozzle becomes clogged with debris, remove the nozzle by unscrewing the two Deck Box lid retaining screws.
2. Remove the Deck Box lid assembly and place on the deck. Disconnect the two ½" unions located on the bottom of the jet assembly.

3. Using a garden hose, place the hose over the jet nozzle and force water backward through the unit and out the two ½" open unions. This will clear debris buildup.

**NOTE** Avoid damage to the nozzle opening. After clean up, reinstall the unions and reattach the unit to the Deck Box.

### 5.2 Winterization

The Laminar Jet can be winterized in regions that require winterization.

1. Remove the Deck Box lid assembly and unscrew the two ½" unions.
2. Attach the two unions to each other to create an air/water tight system. The Laminar Jet can then be replaced in the Deck Box or may be removed to a storage location. If left in the Deck Box, tape over the slot opening to ensure no water will enter the system. If fiber optic cable is used, be sure to remove the retaining nut on the waterproof fitting on the bottom of the jet assembly.

## Section 6. Parts List and Exploded View

Key No.	Description	Qty.	Order Part No.
1	Laminar Jet Body Coupling Nut O-rings Union O-rings	1 2 2	R0401500
2	Thermoplastic Brackets Screws	2 6	R0401600
3	Coupling Nuts Blank Caps O-rings	2 2 2	R0401700
4	Deck Box Deck Box Lid Screws	1 2	R0401800
5	Hayco Fitting Complete	1	R0401900
6	Hardware Kit Laminar Jet Body Screws Bracket Screws Deck Box Lid Screws Union O-rings Coupling Nut O-rings Laminar Jet Body O-ring (not shown)	 8 6 2 2 2 1	R0411000
7	Laminar Jet Assembly w/Deck Box	1	JLJ1001
8	Deck Box Lid, Pebble Deck Box Collar, Pebble	1 1	JLJL1001
9	JLJL Deck Box Lid, Pewter	1	JLJL1002
or	JLJL Deck Box Lid, Black	1	JLJL1003

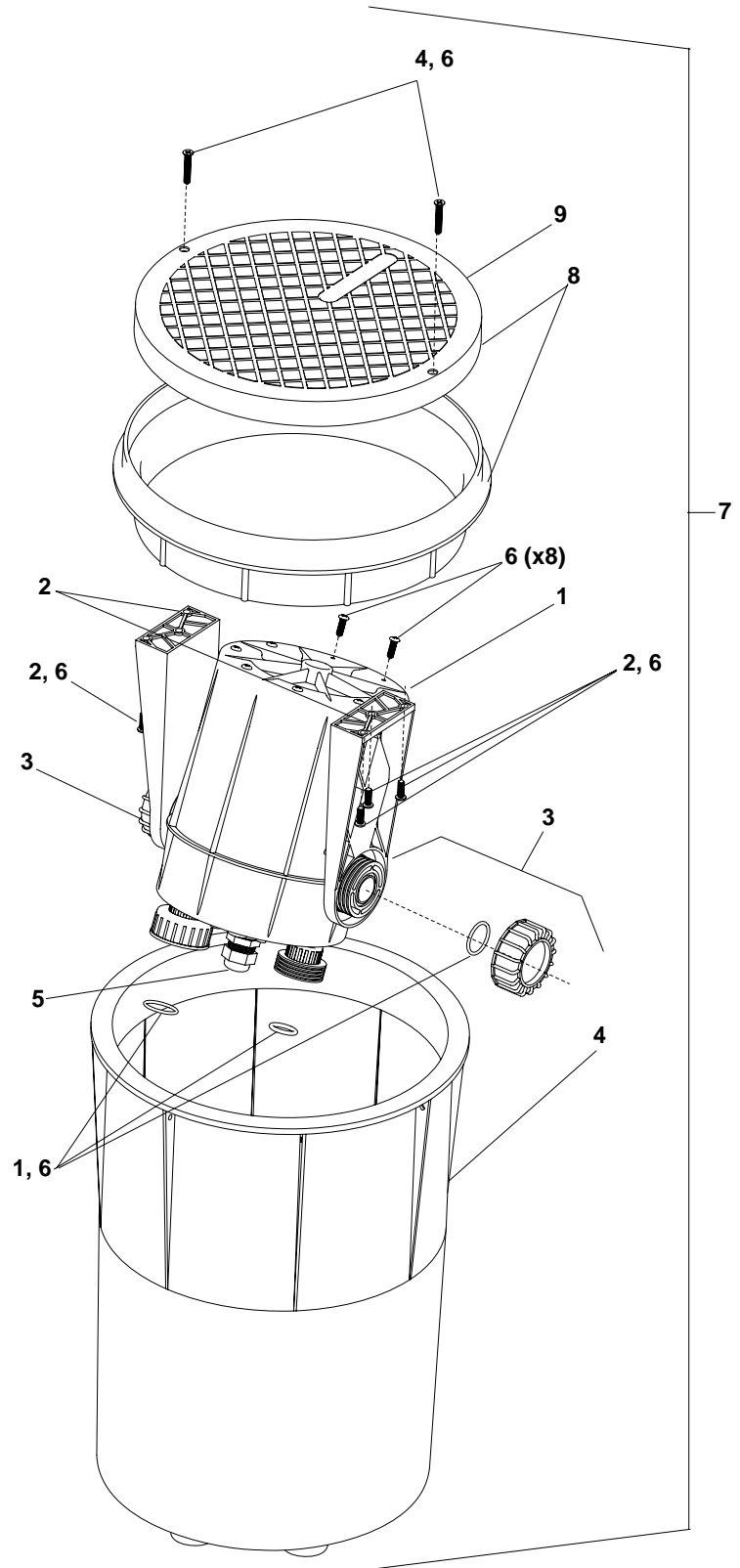



## LIMITED WARRANTY

Thank you for purchasing Jandy® pool and spa products. Jandy Pool Products, Inc. warrants all parts to be free from manufacturing defects in materials and workmanship for a period of one year from the date of retail purchase, with the following exceptions:

- AquaLink® RS units installed with Jandy Surge Protection Kits will be covered for two years.
- NeverLube® valves are warranted for the life of pool and/or spa on which they were originally installed.
- AquaPure™ Electronic Chlorine Generator Electrolytic Cells carry a 5 year limited warranty on a prorated basis.

This warranty is limited to the first retail purchaser, is not transferable, and does not apply to products that have been moved from their original installation sites. The liability of Jandy Pool Products, Inc. shall not exceed the repair or replacement of defective parts and does not include any costs for labor to remove and reinstall the defective part, transportation to or from the factory, and any other materials required to make the repair. This warranty does not cover failures or malfunctions resulting from the following:

1. Failure to properly install, operate or maintain the product(s) in accordance with our published Installation, Operation and Maintenance Manuals provided with the product(s).
2. The workmanship of any installer of the product(s).
3. Not maintaining a proper chemical balance in your pool and/or spa [pH level between 7.2 and 7.8, Total Alkalinity (TA) between 80 to 120 ppm, Total Dissolved Solids (TDS) less than 2000 not including salt ppm].
4. Abuse, alteration, accident, fire, flood, lightning, rodents, insects, negligence or acts of God.
5. Scaling, freezing, or other conditions causing inadequate water circulation.
6. Operating the product(s) at water flow rates outside the published minimum and maximum specifications.
7. Use of non-factory authorized parts or accessories in conjunction with the product(s).
8. Chemical contamination of combustion air or improper use of sanitizing chemicals, such as introducing sanitizing chemicals upstream of the heater and cleaner hose or through the skimmer.
9. Overheating; incorrect wire runs; improper electrical supply; collateral damage caused by failure of O-Rings, DE grids, or cartridge elements; or damage caused by running the pump with insufficient quantities of water.

### LIMITATION OF LIABILITY:

This is the only warranty given by Jandy Pool Products, Inc. No one is authorized to make any other warranties on behalf of Jandy Pool Products, Inc. **THIS WARRANTY IS IN LIEU OF ALL OTHER WARRANTIES, EXPRESSED OR IMPLIED, INCLUDING BUT NOT LIMITED TO ANY IMPLIED WARRANTIES OF FITNESS FOR A PARTICULAR PURPOSE AND MERCHANTABILITY. JANDY POOL PRODUCTS, INC. EXPRESSLY DISCLAIMS AND EXCLUDES ANY LIABILITY FOR CONSEQUENTIAL, INCIDENTAL, INDIRECT OR PUNITIVE DAMAGES FOR BREACH OF ANY EXPRESSED OR IMPLIED WARRANTY.** This warranty gives you specific legal rights. You may also have other rights which vary by state or province.

### WARRANTY CLAIMS:

For prompt warranty consideration, contact your dealer and provide the following information: proof of purchase, model number, serial number and date of installation. The installer will contact the factory for instructions regarding the claim and to determine the location of the nearest designated service center. If the dealer is not available, you can locate a service center in your area by visiting [www.jandy.com](http://www.jandy.com) or by calling our technical support department at (707) 776-8200 extension 260. All returned parts must have a Returned Material Authorization number to be evaluated under the terms of this warranty.