

Customer Satisfaction Primer

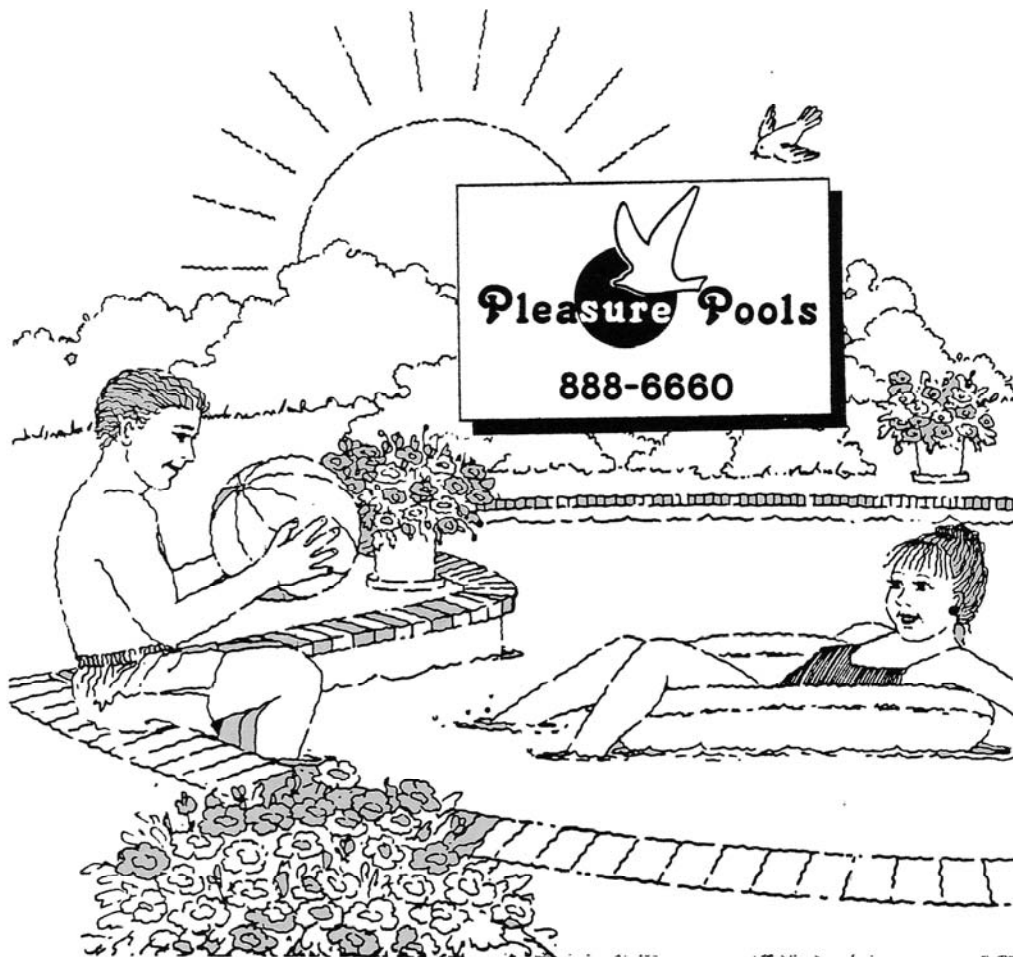

**Our Guide to Successful Operation of
Your Swimming
Pool**

CONGRATULATIONS:

All of the fun and excitement that you have dreamed about has finally become a reality. We want to compliment you on your very wise investment in family health and recreation. The staff at Pleasure Pools Southshore and Northshore invites you to call us when you have questions on the operation and maintenance of your pool. We would rather provide you with information and advice, rather than expensive parts and repairs.

OUR JOB:

- #1. To create a state-of-the-art swimming pool that looks great, and works exceptionally well, saving you time and money on maintenance and repairs.
- #2. To provide all of the tools and information that is required to keep your pool water clean and clear, and your equipment operating properly.

YOUR JOB:

- #1. To take advantage of the equipment and all of the information we have provided by LEARNING how to maintain your pool.
- #2. After participating in the “Pool School” we have provided, and reading this manual, DOING the things we recommend in this manual. This maintenance program will allow you to enjoy your pool, rather than resolving problems.

COMMON MISTAKES **(THAT LEAD TO BIG PROBLEMS)**

- #1. Not running your pump long enough. Your filter, heater, automatic pool cleaner, and chlorinator will not work unless your pump is operating efficiently. We provide 2-speed pumps and recommend that you run your pump 24 – 7.
- #2. Not maintaining the proper water level in your pool. When the water level in your pool is at or near the bottom of your tile line in your pool, the pump begins to draw air (instead of water) into your circulating system. This causes your pump to lose it’s “prime.” When the pump loses it’s prime, water is no longer moving through the circulating system and none of your equipment is working. CAUTION: The water inside of your pump housing can reach over 200 degrees if your pump runs for an extended period of time without a “prime.” This occurs because of the friction between the rapidly moving pump impeller and the water that is not moving. The heat and the steam created can melt piping, fittings, and your pump. If you open the pump strainer, SCALDING WATER CAN SPRAY OUT WITH DISASTEROUS RESULTS!!! Never open the strainer housing on your pump if you even think that this condition might exist. Turn the pump off and wait for the water to cool before opening the pump strainer housing.
- #3. Not adding pH adjustment chemicals to your pool water. Salt chlorination raises the pH of your water. If you don’t add enough muratic acid to your pool water on weekly basis, YOU WILL DEVELOP SCALE. Scale will appear as white streaks and encrustations on your pool plaster. This will be especially troublesome on colored plaster pools.

- #4. **Not cleaning your pump strainer basket:** If this basket is not cleaned regularly, and re-inserted properly, debris will clog the impeller and the pump will not perform properly. This is a normal maintenance procedure that you have to perform. Problems associated with process will not be covered by any warranty.

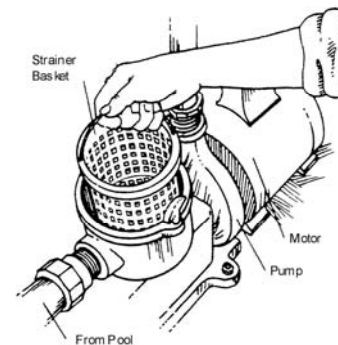

- #5. **Not cleaning your chlorinator cell.** When the cell becomes encrusted with calcium and other minerals dissolved in your water, the chlorinator will not work.

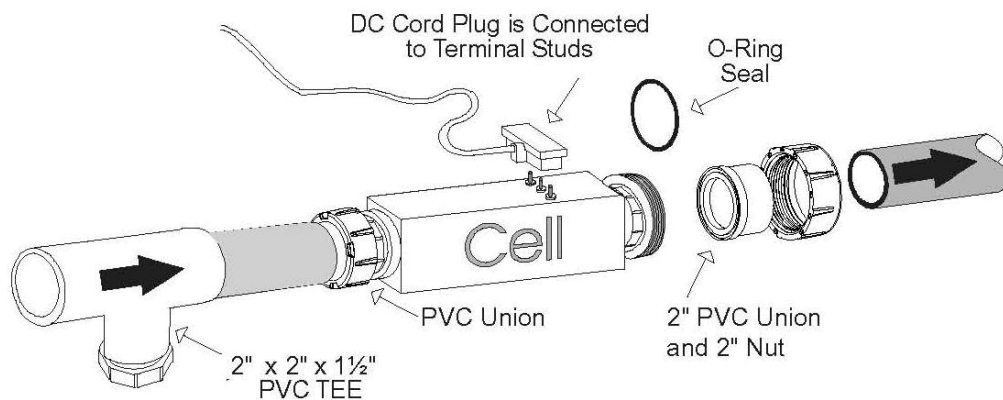

You must disconnect the cell and clean it with muratic acid! (See your Owner's Manual)

- #6. **Not cleaning your filter elements:** As your filter elements get dirtier, it becomes harder for the water to pass through. Eventually, this will shut your whole system down. When your filter pressure becomes 10 pounds higher than it was when the elements are clean, it is time to clean your elements. Be careful when you re-assemble the filter tank. Unless the procedure specifically recommended in the manual is followed, leaks and other problems will occur.



Page 3

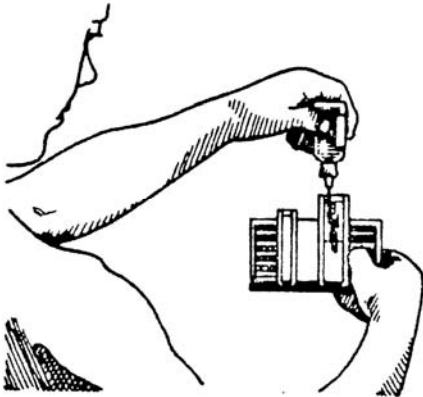

- #7. **Not testing your water:** You CANNOT determine the condition of your pool water by looking at it. When your water is cloudy or green, it certainly needs attention, but your water can be hazardous to your health, even if it “looks” good. Weekly testing of your water, followed up by monthly testing by your local pool chemical store, is the only way to keep your water up. A little time and money spent on adjustment chemicals can save you lots of money in the long run.

WARRANTY: Pool problems that develop due to errors or omissions in your operation of the pool are NOT WARRANTY ITEMS. Almost 90% of the pool “problems” that are reported to us, are due to a lack of basic pool maintenance. That is why we, as a company, go to extreme lengths to provide you with the training, tools, and the information that you need to properly maintain your pool. The “bottom-line”, however, is that we cannot maintain your pool for you. Unless you, or someone in your employ, performs the basic procedures that we outline here, you will continue to have problems and you will become very dissatisfied with your pool.

- #1. **Mechanical Warranties:** Any item that is manufactured, like your pump, for example, is covered by a “manufacturer’s warranty.” Problems with mechanical equipment are normally taken care of by warranty centers, such as Pelican Pool Service, in Metairie, or The Pool Store, in Mandeville.
- #2. **Product Warranties:** Pleasure Pools will consider warranty claims on any work that we perform that is deficient in quality or workmanship.

Leaks and Water Loss: It is not unusual for your pool to “lose” up to ¼” of water per day. We often get complaints about water loss that end up being only “splash-out” due to use, or natural evaporation. The amount of water your pool loses is dependent upon the

temperature of the air, the temperature of your water, the relative humidity, wind direction and velocity, etc. The rate is variable, so it is understandable if you become concerned that your pool suddenly “loses” a large quantity of water. If you suspect that you have unexplainable water loss, it is a good idea to document it over a 24 hour period, and then call us to check it out. If the suspected leak is not obvious, we will turn the problem over to a professional leak detection service. When the service determines where the loss is occurring, we will make the appropriate repair. If the service determines that your pool, contrary to your report, does not leak, you will be expected to pay for the leak detection service.

Chapter 1: STARTING UP YOUR NEW POOL

FILLING YOUR POOL: We will need a garden hose (supplied by you) to begin the initial filling process of your pool. A soft cloth will normally be tied to the end of the hose to diffuse the water pressure as your pool fills. The hose end will be placed on the main drain grate in the deep end of your pool. This hose should not be moved for the first 12 hours of the filling process. The water should be added continuously to the pool or you will develop a “bathtub ring” or line in the plaster that cannot be removed. If you are afraid that the pool might overflow at night while you are asleep, reduce the flow to the pool to a trickle. Do not place a second hose in the pool, or move the first hose until the second day of filling.

MAINTENANCE OF YOUR NEW PLASTER: We will add the chemicals that are required for the initial balancing of your water. Brushing the plaster with the nylon-bristle brush we provide will greatly improve the quality of your plaster. It will also prevent the build-up of the normal precipitation of calcium and other minerals in your pool water. If you notice that you have a fine “sand” deposited on the bottom of your pool, it is more than likely that this is the “precipitation” that we have referred to. We will brush the pool on each visit, but it is not feasible for us to provide the recommended twice per day brushing for the first seven days.

POOL SCHOOL: After the initial start-up, our service technician will attempt to schedule an appointment with you to teach you how to maintain your pool. This session will normally last about one hour, and should include all members of your family that will be involved in maintaining your pool. If you are unwilling or unable to schedule with our technician, this does not release you from the responsibility of maintaining your pool. After our first attempt to schedule, it will be your responsibility to re-schedule.

WATER CHEMISTRY AND YOUR PLASTER:

What is pH? Simply speaking, pH is a measure of how acidic or how alkaline your water is. On this scale that runs from “0” to “14”, a reading of “7” indicates that your water is neutral(neither acidic or alkaline). As the reading gets below

“7”, the water becomes increasingly acidic and as it rises above “7”, it becomes increasingly alkaline. The recommended pH is slightly alkaline, or 7.4-7.6. How Does pH Affect Your Plaster? Water that is below 7.0 will tend to erode or remove the smooth patina from the plaster surface. Water that is above 8.0 will contribute to the formation of scale and stains. In addition, your Chlorine will be more effective in killing germs and eliminating algae when your pH is in the proper range.

The Importance of Calcium: Calcium is one of the key elements found in both your pool water, and in your plaster. It exists in equilibrium; if the water has too much calcium, it will cause deposits on your plaster and if the water has too little, it will take calcium out of the plaster, weakening it. Proper calcium is 250 ppm.

Page 5

Dissolved Metals: Stains that cannot be removed by bleaching are generally metal stains. When the water becomes saturated with any metal, such as copper or iron, it will generally “precipitate” or fall out of solution in the form of a metal stain. Copper stains usually reveal themselves as blue or blue-green splotches or streaks, whereas iron is usually brown to black. Acidic water or high concentrations in your make-up water is the usual culprit. Check with your pool store to purchase chemicals that will prevent these stains.

Mottling: Mottling occurs naturally in most pools. It is more evident in colored plaster pools, but not more prevalent. There are strategies that can be employed to lessen the mottling, such as sequestering, chelating, or pH and calcium reduction.

Total Alkalinity: Your total alkalinity should be tested on a regular basis by a pool chemical store. Proper total alkalinity promotes stable pH readings and will eliminate drastic changes in pH that will consequently affect water quality.

PLASTER WARRANTY: If your plaster is not stained, etched, or chipped when we turn the pool over to you, and it subsequently develops these problems, it is likely that the cause is poor maintenance procedures, not poor workmanship. We will not warranty any perceived plaster problem that is naturally occurring or that comes from improper maintenance.

Organic Stains: Nearby plants will often cause your plaster to become stained with tannic acid (brown) and Chlorophyll (green) stains. These organic stains will not remain for a long period of time, due to the fact that Chlorine will eventually bleach them out.

Plaster Checking or Cracks: It is not uncommon, especially if your pool was plastered on a very hot day, or if you drain your pool for any reason, to develop tiny, hair-line cracks or checking of your plaster. This is not a defect, but rather a natural occurrence due to the shrinkage of plaster after application. Since concrete is somewhat flexible, your pool may be under some stress due to settling of some of the supporting soil. We may elect to

fill the crack with underwater setting putty if it is large enough, but this occurrence is not a defect in the plaster and will not be warranted as such.



Chapter 2: GET TO KNOW YOUR POOL EQUIPMENT:

We use Jandy Pool Products, exclusively, not because it is the cheapest, but because we believe that it is the best.

Our relationship with Jandy is one of loyalty and trust, which pays dividends in the long run for us and for our customers. The following is a brief outline of the pool equipment that will be used in your pool, the purpose of each piece of equipment, along with some helpful operating hints. The complete Owner's Manual for each component can be found on our web-site.

#1. JANDY STEALTH PUMP:



Your pump is the device that draws water from your skimmer (located in the sides of your pool) and your main drain (located on the bottom of your pool (and spa, if you have one), and returns this filtered, heated, and chlorinated water to the pool through strategically located "jets" or "returns" in your pool wall.

Operating Notes:

- a) Your Pump Strainer Basket (shown at the top of page 2) is a very important part of your circulating system. It prevents the pump impeller (the part that

pushes the water through the system) from becoming clogged with debris. If the basket is inserted improperly or if it becomes clogged, you will have problems with your pump. Improper insertion of the basket will cause debris to by-pass the basket, lodge in the impeller, and affect the efficiency of the pump. Note the slot in the strainer basket, and line up the slot with the tab in the strainer opening. The basket should slide in place easily. If the basket becomes filled with debris, it will affect the delivery of water to the pool and could cause the pump to fail to pump any water at all. Both of these problems will affect the operation of all pool components. It is possible that you will see an air bubble floating on the top of your clear pump strainer lid. It is also possible that you will see no bubble, and the pump strainer basket will appear to hold no water at all. Neither of these observations indicates that there is a problem.

If no air bubbles are appearing in the pool, you can disregard the air bubble under the lid, and if you see movement of the water through the jets in the pool, you can disregard the “empty” pump strainer basket. If your filter is indicating normal pressure on your filter, you have nothing to worry about, providing it is in the proper range (to be explained in the “filter” section).

b) Keeping your pump “Primed.” Quite simply, when your pump is “primed” it is actively and efficiently pumping water. Evidence of your pump being primed is that you see water moving in the pool and pressure on your filter gauge.

Running your pump for extended periods of time without a prime voids the warranty on the pump and the pipes attached to it.

c) How Does Your Pump **SOUND**? A very good indication of your pumps performance can be determined by listening to the sound it makes when it is running. Noisy pump operation indicates a problem with performance. Call a technician to diagnose your problem before permanent damage is done.

#2. **Cartridge Filter:** Your filter traps debris much like air and oil filters do. The water passes through several pleated mesh filter elements that trap fine particles in your water. As the filters pick up these particles, it becomes harder for the water to pass through the elements. For this reason, it is important for you to record your filter pressure (the pressure on your filter gauge located at the top of the filter) when your filter is clean. A good time to do this is when your filter is started up for the first time. As a rule-of-thumb, you can allow your filter pressure to increase up to 10 pounds over the start-up, or clean filter pressure. At this point, you should disassemble the filter elements and clean them thoroughly with a garden hose and nozzle. Instructions for cleaning will be found in the Owner’s Manual Section of this same web-site. Once or twice a year, it is also important to de-grease your elements by soaking them in detergent. These elements, just like any other filter will accumulate body oils as they age.

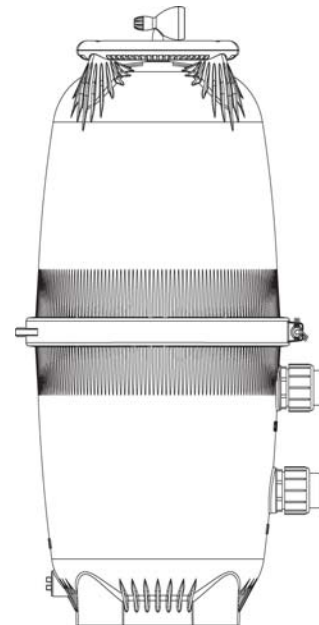

#3. **Salt Chlorinating System:** Your salt system can be your best friend or your worst enemy, depending on how you maintain it. The salt cell HAS TO BE CLEANED! If your pump is running long enough, and it is pumping water efficiently, and you have the proper amount of salt in the water (3000 ppm), and your cell is clean, there is a 99% chance that your chlorinator will produce chlorine. If you are sure that all of the above parameters are met, and the chlorinator is still not working, then call us. Please do not call us to inspect a cell that has never been cleaned. The cleaning procedure will be completely outlined by the start-up tech.

Approximate Pounds (kg) of Salt Needed to Maintain 3.0 gpl (3,000 PPM)

Salt Concentration Before Addition	Salt Addition Required per 1000 gallon pool capacity	Salt Concentration Before Addition	Salt Addition Required per 1000 gallon pool capacity
0.0 gpl	25.6 lbs (11.6 kg)	1.5 gpl	12.8 lbs (5.8 kg)
0.3 gpl	23.5 lbs (10.7 kg)	1.8 gpl	10.7 lbs (4.8 kg)
0.5 gpl	21.4 lbs (9.7 kg)	2.0 gpl	8.5 lbs (3.9 kg)

#4. **Surface Skimmers:** The surface skimmers perform two very important services. First, they accelerate the circulation of your “surface” pool water. Since your water comes in contact with 90% of the contaminants on the surface, accelerating the surface circulation improves your overall ability to filter and chlorinate the water. Secondly, the skimmer door or weir, along with the skimmer basket, provides an entrapment device for floating debris.

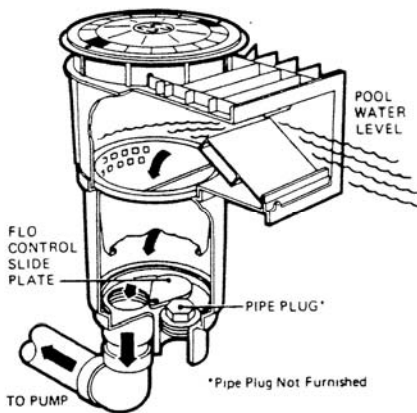

In order for the skimmer to perform properly, the water in your pool should be at the mid-line of the tile, and your skimmer door or weir must be functional. Once the skimmer baskets are full, however, the skimmer ceases to function at all. In the fall, leafy situations may require daily cleaning. When the water gets to the bottom of the skimmer mouth, your pump may lose its “prime” and cause your pump to run dry. This may cause irreversible damage to the pump and create a dangerous situation, should steam develop due to the pump overheating the water.

Do not open the pump strainer lid if you believe that steam has built up inside of the pump.

#5. **Main Drains:** Although inconspicuous and sometimes forgotten, the main drains are an integral and important part of your circulating system. Placed at the lowest or deepest part of your pool, they are the major collecting point for dirt and debris that has escaped the pool cleaner or the skimmer. In some cases, leaves and other solid debris may completely clog the drain grates, making the drain inoperable. When this occurs, you should immediately use your brush or vacuum to clean it.

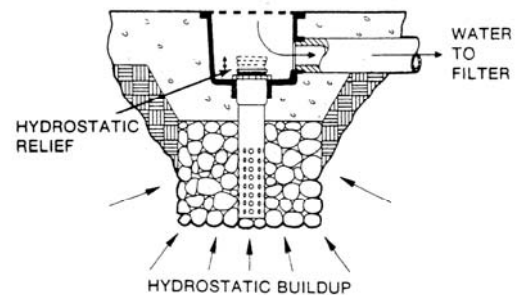

IMPORTANT NOTE: We will always install grates or

slotted covers on top of your main drains. These can come loose, however, and if they do, they should be replaced immediately. Their loss or removal can be an entrapment hazard which could result in drowning. Never let anyone swim in your pool if these grates are damaged, loose, or removed. Call us immediately and we will replace them for you.



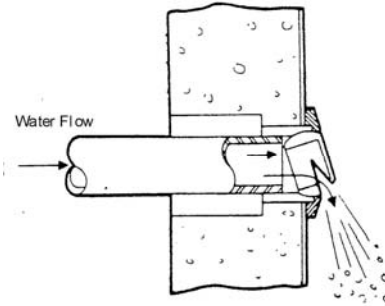

#6. Inlet Fittings or Returns: These fittings direct the flow of water back to the pool. They will be set to face properly by the start-up technician, and they should be replaced or re-adjusted as needed. Without the circular rotation they provide, your filtration system and your skimmers and main drains will not function to capacity.

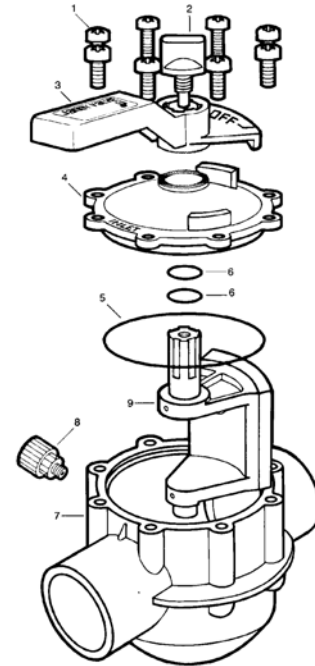

Page 9

#7. Jandy Flow Control Valves: The expensive flow-control valves we use are permanently lubricated and turn very easily to help you control the flow through the suction side of your pump. If you have any problems with them, they can be disassembled. You should notice that these valves close differently than ball valves. When the valve handle of this valve points in the same direction that the pipe is running, the valve is “closed”. When the valve handle is perpendicular to the direction of the pipe, the valve is “open”. These valves are intended to be used to regulate the flow of water to the suction side of the pump. By using these valves properly, you can balance the flow of your skimmers, or vacuum your pool, or accentuate the flow from your main drains, or from your skimmers. If all of these valves are closed, the pump will not get any water. It will not allow any water to flow through the pump, and it will overheat, causing damage to the pump.



Pool Digital Assistant (PDA) System Sub-Assembly		
		
PDA Handheld Remote	Outdoor Transceiver J-box	Power Center PCB
		
Two (2) Temp Sensors, Additional Relays (Model Dependent)	Two (2) JVs (With Pool/Spa Combination Only)	

- #9. **Electronic Controller / PDA:** You may have one of several models of our Jandy PDA units. They are certainly a little more complex than the old mechanical pump timers, but they offer so much more. With the Jandy PDA Controller, you will be able to do the following:
- Turn on or off all mechanical devices remotely or at the filter.
 - Program all mechanical devices to come on or turn off at the time you set them
 - Set the operating level for your salt chlorinator
 - Inspect the salt level and the air and water temperature at a glance
 - Control auxiliary items that may be added later.
 - The unit will turn on your pump automatically at 34 degrees

#10. **Color-Blend Pool and Spa Lights:**

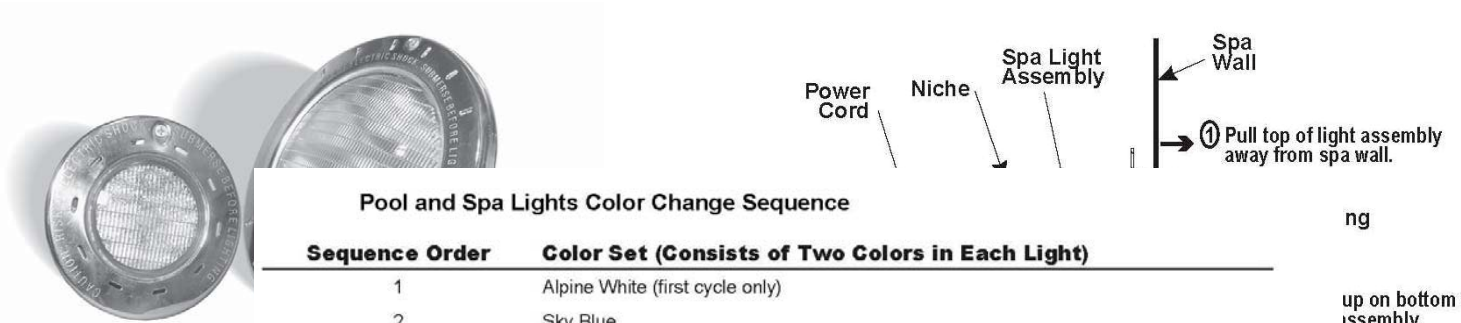

Pool and Spa Lights Color Change Sequence

Sequence Order	Color Set (Consists of Two Colors in Each Light)
1	Alpine White (first cycle only)
2	Sky Blue
3	Cobalt Blue
4	Caribbean Blue
5	Spring Green
6	Emerald Green
7	Emerald Rose
8	Magenta
9	Garnet Red
10	Violet (color remains active approximately 4 minutes)

ng

up on bottom of assembly.

ement

NOTE When the light is first turned on, the sequence ends at Violet and at the next rotation, starts at Sky Blue. Alpine White is not included in subsequent cycles.

When the light is turned off, it will remain in the color set that is currently active. When the light is turned back on, the color change sequence will start with the color set that was last active. For example, if the light is turned off when Cobalt Blue color set is active, then Cobalt Blue will be the first color set in the change sequence when the light is turned on again.

6.2 To Lock On a Specific Color Set

Wait until the desired color is ON during the *first cycle of color change*. Turn the light OFF, wait 2 seconds and then turn the light back ON. Wait 10 seconds before turning the light off so that the color will not reset.

NOTE If a specific color is not locked on during first cycle of colors, the light will continue to follow the color change sequence. To choose a color *after* the first cycle, the light must be reset.

If you encounter a dimmed light, the light was probably turned off during in the middle of the color transition. To resolve this situation, turn the light off for 3 seconds, then turn it back on. The light will return to full power.

6.3 To Initiate a New Cycle or Reset from a Locked Color

Turn the light OFF, wait 2 seconds, then turn ON, wait 2 seconds, then turn OFF, wait 2 seconds, and then turn ON again. The light will return to beginning of the color cycle (Alpine White) and continue with the normal light sequence (see Table 1 in Section 6.1).

NOTE To synchronize colors on multiple **Jandy Pool and Spa Light** systems wired to separate switches, perform the above actions on all of their switches simultaneously. All **Jandy Digital Pool and Spa Lights** will synchronize automatically if activated off of the same switch. No other accessories are required.

#11. Gas Pool Heaters

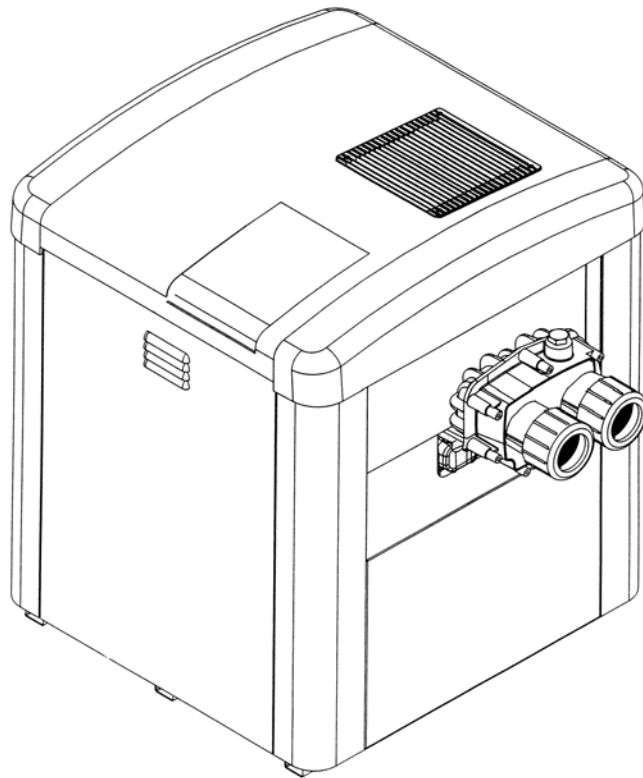

Your gas heater will only operate if the following factors exist:

- a) Your pump must be operating efficiently
- b) Your filter must be clean
- c) Your Electronic Controller (PDA) must have the temperature set high enough to activate the heater

Therefore, if your pump strainer basket is full o leaves, or if your filter is dirty, or if your pump is not primed, your heater will not work. If your controller has your pool set to come up to 85 degrees and your water is already 86 degrees, your heater will not work.

One problem that has become much more prevalent lately is insufficient gas supply to the heater. In order for a gas heater to work properly, a commercial gas meter will be required. In addition, a “dedicated” line of sufficient size is absolutely necessary for the heater to function.

Pool heaters work by re-cycling water, so the water will not be hot to the touch when it comes through the pool jets or inlets. Heat is added gradually as the water is turned over in the pool.

Page 12

#12. **Heat Pump:** Your heat pump runs on electricity. It requires 50 to 60 amps to run properly. Although it is much more economical to operate a heat pump, it heats your pool much slower than a gas-fired heater. Heat pumps are usually rated anywhere from 90,000 to 150,000 BTU’s, whereas a gas heater is typically between 250,000 to 400,000 BTU’s. Heat pumps, used in conjunction with a “solar blanket”, opens the door to swimming on a daily basis in 85 degree water. Like a gas heater, the heat pump has the same requirements to operate. The pump must be operating efficiently, the filter must be clean, and the thermostat must be high enough to activate the heater.

Our Most Common Complaint About Heat Pumps:

THE HEAT PUMP IS NOT WORKING!!!

IF THE FAN IS TURNING AND IT IS BLOWING OUT COOL, DE-HUMIDIFIED AIR:

IT IS WORKING!

YOU JUST HAVE TO GIVE IT MORE TIME.

Heat Pumps, just as Air Conditioning units, create condensation. It is normal to have water leaking from the outlet at the bottom of the heater.



#13 **Polaris 280 Automatic Pool Cleaner:** Your “Automatic” Pool Cleaner is not totally automatic. It requires that you clean out the collection bag when it is full. If you don’t clean this bag, the cleaner will not pick up any more debris and, in addition, the extra weight in the bag will probably cause it to tear. The hand-tightened couplers that hold the hose together will occasionally come un-done. When this happens, you will usually find the missing coupler in the pool, or the unit may have picked it up itself. Placing the couplers back on is a simple task that will have to be performed occasionally. There is also an in-line

strainer that prevents dirt from getting to the gear mechanism in the unit. This strainer will have to be cleaned out periodically.

Polaris 280 Complete Cleaner

- | | |
|-----------------------------|--|
| 1. All-Purpose Zippered Bag | 7. Hose Floats |
| 2. Head Float | 8. Back-up Valve |
| 3. Sweep Hose | 9. In-Line Filter Assembly |
| 4. Sweep Hose Scrubber | 10. Quick Disconnect with Universal Wall Fitting (UWF) |
| 5. Cleaner Body | 11. Restrictor Disks (one red and one blue) |
| 6. Feed Hose | |

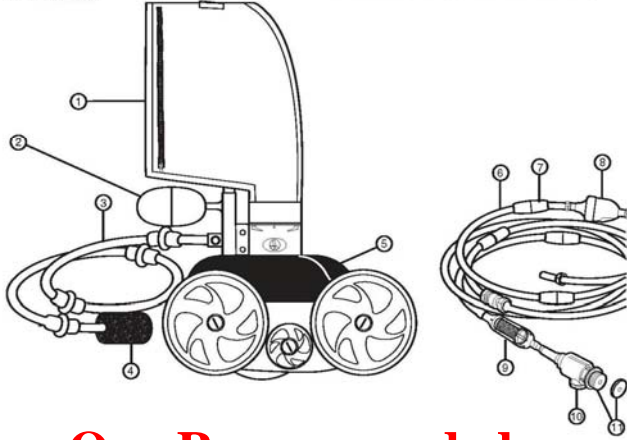

Adjust Feed Hose To Fit Pool Length

Measure the deepest part of the pool. Cut leader hose, from end that attaches to feed hose, so length is equal to the greatest depth of the pool.

Attach leader hose to feed hose and connect hose to the pool wall at the return line. Extend hose to farthest point of pool. The hose end must be within 6" – longer or shorter – of the farthest point. See dotted circle.

Hose too long? Separate hose at center swivel. Cut equal amounts of the overage from each 10-foot feed hose section.

Hose too short? Buy an additional feed hose section (part #9-100-3104), one swivel (part #D20) and two hose nuts (part #D15) from an authorized Polaris dealer.

After adjusting hose, position hose floats as shown.

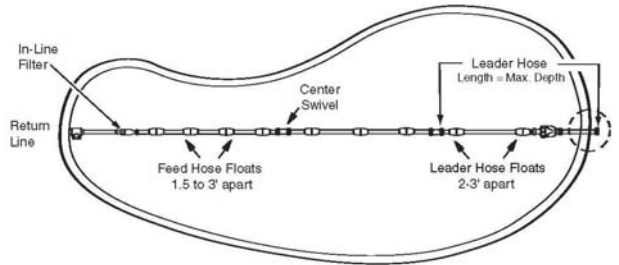

Our Recommended Maintenance Regimen

Page 13

If performed properly and regularly, your maintenance regimen should last about 30 to 45 minutes once each week. You can perform these tasks or you can hire someone to do them for you, BUT THEY MUST BE PERFORMED!!

ONCE EACH WEEK:

- 1) Test the water for sanitizer (chlorine) content and pH
- 2) Adjust water chemistry accordingly.
- 3) Clean the Pump Strainer Basket
- 4) Clean the Skimmer Baskets
- 5) Vacuum the pool bottom and sides
- 6) Brush the pool bottom and sides
- 7) Add or remove water as needed for proper skimmer operation.
- 8) Clean the tile-line
- 9) Skim the pool surface
- 10) Clean the filter as needed (not necessarily every week)

ONCE EVERY OTHER MONTH:

It is very important that at least every other month you avail yourself to the free water testing that is available at full-service pool stores. They can test your water for total alkalinity, calcium hardness, stabilizer, iron, copper, total dissolved solids, free chlorine, total chlorine, pH, clarity, and the presence of algae. The time and effort you expend will pay huge dividends in the long run. Plaster life, proper filtration and proper water sanitation can be greatly enhanced by diligence in this area. This is also the area where your builder has no control, but I can assure you that neglect in this area is just as serious

and costly as not having your automobile serviced. Low pH and calcium levels can destroy the best plaster job in a year or less. High iron or copper levels can cause ugly stains. Low sanitizer levels or improper pH can lead to the transmission of viruses and bacteria from one person to another in the pool.

GET TO KNOW YOUR LOCAL FULL-SERVICE POOL STORE!!!

HOW TO VACUUM YOUR SWIMMING POOL:

ITEMS YO NEED: Telescoping pole, vacuum head, and your vacuum hose.

GETTING READY: Place these items next to the skimmer you want to use.

DOING IT:

1. Attach the vacuum head to the pole.
2. Attach the vacuum hose to the vacuum head.
3. Place the vacuum head on the pool bottom and using a hand-over-hand

Page 14

Method, sink your vacuum hose, starting with the part closest to the vacuum head, and working towards the free end of the hose. This will remove all of the air from the vacuum hose. Water should run out of the hose if you have done this properly.

4. Remove the skimmer basket and place the free end of the hose into the opening at the rear of the skimmer. (only one hole will have suction)
5. Go to the filter slab and turn the main drain control valve off.
6. Turn the control valve that is attached to the skimmer you are not using to vacuum towards the off position until you hear the pump cavitate. Open it slightly past that point until the pump runs smoothly again. You have now concentrated most of the pump suction into your vacuuming system.
7. Make slow patterned passes across the bottom and sides of the pool. If the pool is very dirty, you may have to stop the pump to clean out the pump strainer or even clean the filter before proceeding.
8. When you are through, go to the filter slab first and open the valves you closed. Remove the vacuum hose from the skimmer first, before removing the vacuum head from the pool. Removing the vacuum head from the pool when actively vacuuming or before removing the hose from the skimmer can cause the pump to lose its prime and make it very difficult to re-prime. Call your service company to re-prime your pump if this happens. Do not run your pump without a prime.

HOW TO TEST YOUR POOL WATER:

Begin by inverting the clear plastic testing block and submerging it in your pool water about 12 inches to get a sample of water from beneath the surface. This will more accurately reflect your true water chemistry than a surface sample. Place 5 drops of the red test chemical on the pH side and 5 drops of the white test chemical on the chlorine side. Compare the colors of the water samples to the color scales on the side and read the appropriate numerical indicators. Your Chlorine level should read 1.5 to 3.0 PPM, adjust your chlorinator appropriately. Your pH should read 7.4 – 7.6. If

your pH is lower than 7.4, you should add 2 pounds of Soda Ash or pH+ to your water and retest several hours later. If your pH is higher than 7.6, you should add one pint of muratic acid to your pool water in the deep end, close to a return jet and retest sever hours later.

CAUTION!!

***NEVER MIX TWO DIFFERENT POOL CHEMICALS TOGETHER**

***BE VERY CAREFUL NOT TO INHALE VAPORS**

***DO NOT SPILL ANY CHEMICALS ON YOUR SKIN OR CLOTHES.**

Page 15

HOW TO CLEAN YOUR FILTER:

Cleaning A Cartridge filter:

Simply open the tank and hose off the elements. The elements may have to be removed to clean them thoroughly but hosing them off first makes them lighter and easier to handle. Be careful not to tear or crush the filter elements. Detailed instructions can be found on our web-site, under the equipment manuals section. Be careful when you re-assemble the filter tank that you clean the o-ring. If the o-ring is dirty, the filter will leak when you re-assemble it. It is also important that you tap the connecting band lightly as you tighten it back up. This will allow the o-ring to slide, rather than pinch

HELPFUL OPERATING HINTS:

*Freezing conditions: Your Aqualink PDA will turn on your pumps when at 34 degrees

*Water Loss: it is normal to lose as much as 1/4" of water per day due to evaporation alone. When splash-out and backdating are added to this, it may seem as though your pool is leaking. If you suspect that you have a leak, mark the pool water level inside the skimmer and measure the water loss over a 24-hour period.

*Noisy Pump Operation: If your pump starts making a lot of noise when it is running, it may be trying to tell you something. Debris in the impeller, bad motor bearings, clogged skimmer or pump strainer baskets will cause noisy pump operation. Damage due to neglect in these areas is not covered by warranty.

*Standard Pump Operation: Run your filter pump 24 hours per day on low-speed. Turning your pump off will save you little money and lead to other problems.

*Green or Cloudy Water: You should be able to see your main drain very clearly at all times. The minute that you notice your water being turbid (cloudy), this indicates that immediate action should be taken. Green water is close behind. Cloudy water indicates improper filtration or improper chlorination. Tend to this immediately.

*Pool Draining: **Never..... Never..... Never.....**

Drain Your Own Pool!!! Call in an experienced professional with insurance.

*Rough Spots In Plaster: If your plaster was smooth when your pool was new and you notice rough areas developing, you probably have water that is corrosive and is consuming your plaster, or you have water that is so saturated with minerals that they are being deposited on your plaster surface.

*Problems or Questions: We will be there to answer your questions or concerns after your pool is completed. Calling us may prevent a small problem from becoming a large problem. Remember, an ounce of prevention = a pound of cure.